

Surname	Centre Number	Candidate Number
First name(s)		0



GCSE

3300U30-1



MONDAY, 9 NOVEMBER 2020 – MORNING

**MATHEMATICS
UNIT 1: NON-CALCULATOR
INTERMEDIATE TIER**

1 hour 45 minutes

ADDITIONAL MATERIALS

The use of a calculator is not permitted in this examination.
A ruler, protractor and a pair of compasses may be required.

INSTRUCTIONS TO CANDIDATES

Use black ink or black ball-point pen. Do not use gel pen or correction fluid.

You may use a pencil for graphs and diagrams only.

Write your name, centre number and candidate number in the spaces at the top of this page.

Answer **all** the questions in the spaces provided.

If you run out of space, use the additional page at the back of the booklet. Question numbers must be given for all work written on the additional page.

Take π as 3.14.

INFORMATION FOR CANDIDATES

You should give details of your method of solution when appropriate.

Unless stated, diagrams are not drawn to scale.

Scale drawing solutions will not be acceptable where you are asked to calculate.

The number of marks is given in brackets at the end of each question or part-question.

In question 8, the assessment will take into account the quality of your linguistic and mathematical organisation, communication and accuracy in writing.

For Examiner's use only		
Question	Maximum Mark	Mark Awarded
1.	4	
2.	4	
3.	6	
4.	3	
5.	4	
6.	3	
7.	3	
8.	6	
9.	5	
10.	3	
11.	5	
12.	3	
13.	4	
14.	6	
15.	3	
16.	5	
17.	6	
18.	4	
19.	3	
Total	80	



NOV203300U30101

Formula List – Intermediate Tier

Area of trapezium = $\frac{1}{2}(a + b)h$



Volume of prism = area of cross-section \times length



1. (a) What is the time 8 hours and 40 minutes after 11:38? [1]

.....
.....
.....

Time is

(b) What is the time difference between 7:35 a.m. and 2:15 p.m. on the same day? Give your answer in hours and minutes. [1]

.....
.....
.....
.....
.....

Time difference is hours and minutes.

(c) Evaluate the time difference between 7 minutes 15 seconds and 2 minutes 50 seconds. Give your answer in seconds. [2]

.....
.....
.....
.....
.....

Time difference is seconds.

3300U301
03



2. (a) Draw the line $x = -4$ on the grid below.

[1]

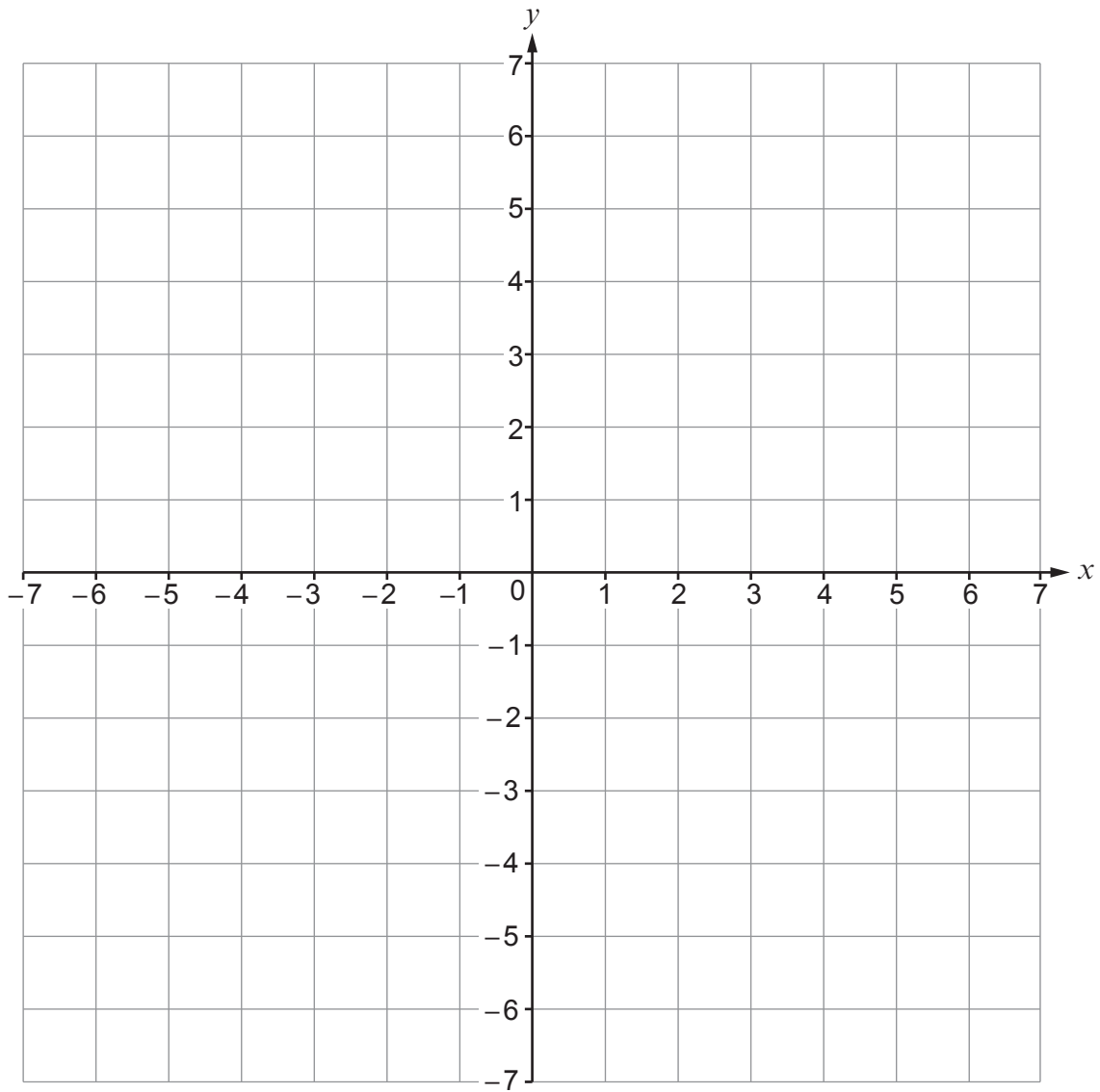

(b) C is a point on the grid below so that:

- $\hat{BAC} = 90^\circ$,
- $AC = AB$.

(i) Show the position of point C on the grid.

[2]

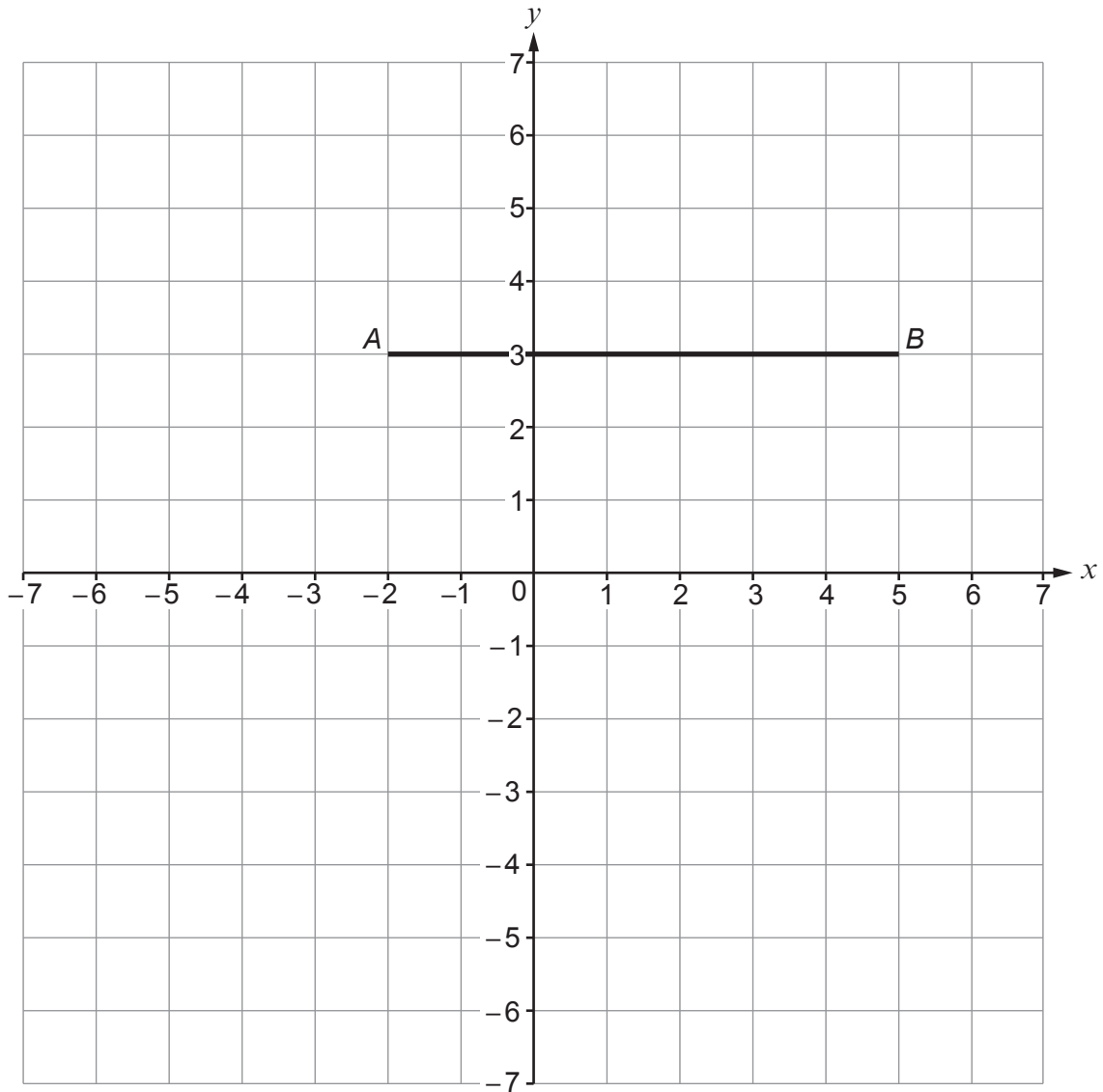

(ii) Write down the coordinates of point C.

[1]

.....



3. (a) Calculate each of the following.

(i) $3^3 \times 10^2$ [2]

.....
.....

(ii) 0.4×0.2 [1]

.....
.....

(iii) $\frac{4}{9} + \frac{5}{18}$ [2]

.....
.....
.....
.....

(b) Write down the value of 0.0493, correct to 1 significant figure. [1]

.....



4. 300 students were asked if they would like to change their school's dinner menu.

The pie chart below shows how they answered.

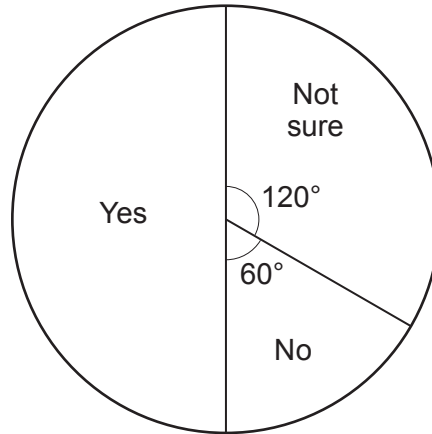

Complete the table below to show the number of students who gave each answer.

[3]

Answer	Yes	No	Not sure
Number of students			

.....

.....

.....

.....

.....

.....

.....



5. (a) Solve the equation $4x + 7 = 10$.

[2]

.....

.....

.....

.....

(b) Simplify $8d - 6e - 3d + 4e$.

[2]

.....

.....

6. PQ and RS are parallel.

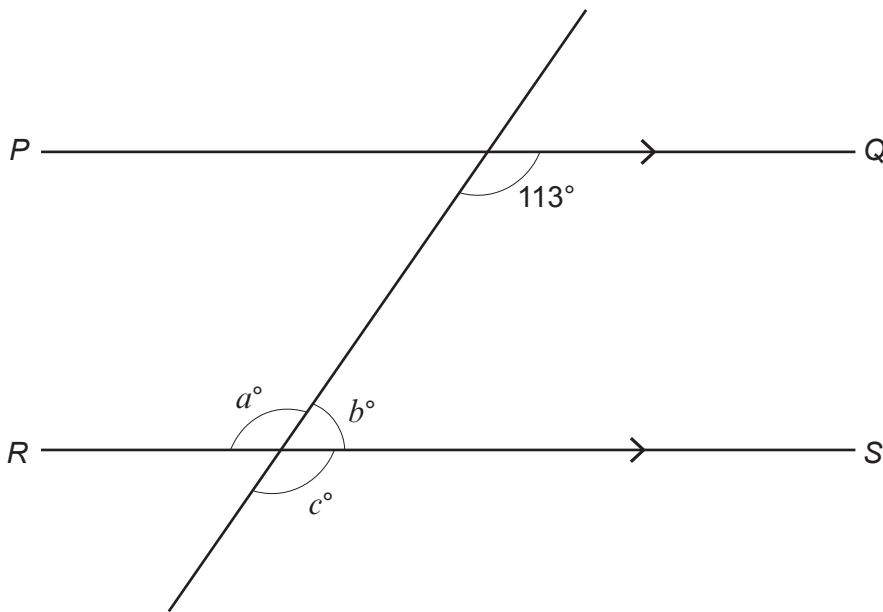

Diagram not drawn to scale

Find the values of a , b and c .

[3]

.....

.....

.....

.....

$a =$ $b =$ $c =$



7. In the diagrams below, $ABCD$ is a square. Triangles ABE and KLM are congruent.

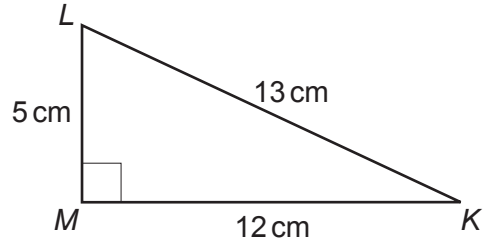
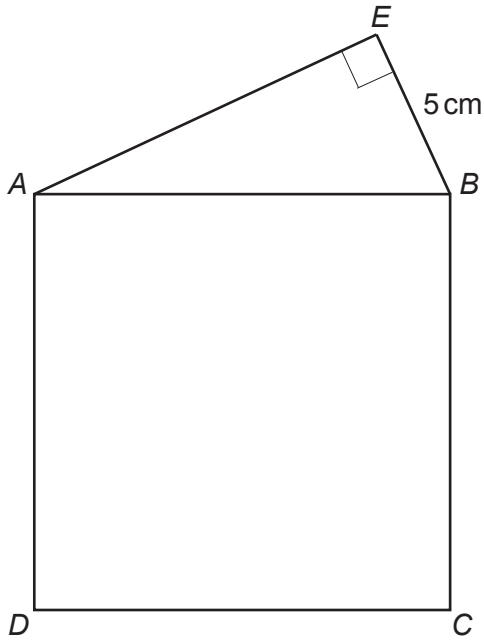

Diagrams not drawn to scale

Calculate the area of the square $ABCD$.

[3]

.....

.....

.....

.....

.....

.....

.....

.....

.....



9. (a) Two sides of a parallelogram $ABCD$ are drawn accurately below. Using only a ruler and a pair of compasses, complete an accurate drawing of the parallelogram. You must show all your construction arcs. [2]

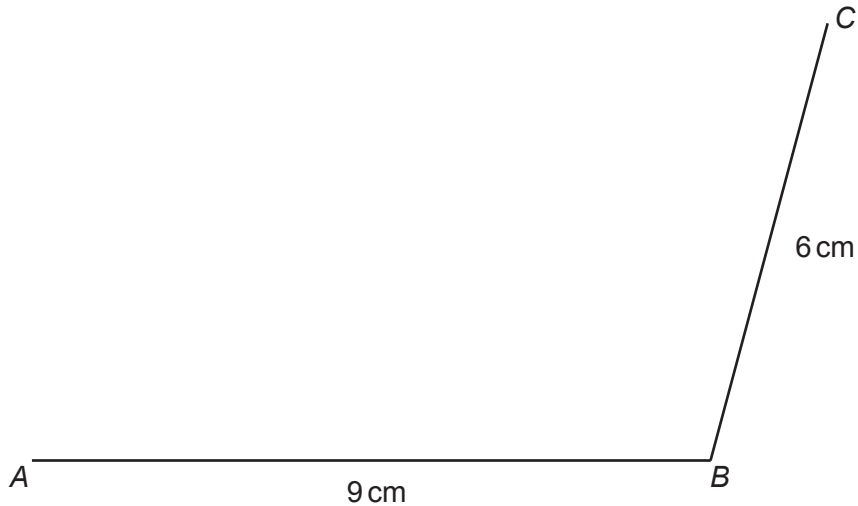

- (b) The line XY below forms part of a scale drawing of a garden. The scale drawing has a scale of 1:200.

What is the actual distance between point X and point Y in the garden? Give your answer in **metres**. [3]

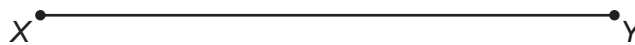

.....

.....

.....

.....

Actual distance between point X and point Y = metres



10. You are given that $543 \times 17 = 9231$.

- (a) What is the value of 5.43×1.7 ?
Circle the correct answer.

[1]

0.9231

9.231

92.31

923.1

9231

.....

.....

- (b) What is the value of $\frac{9231}{54.3}$?

Circle the correct answer.

[1]

0.17

1.7

17

170

1700

.....

.....

- (c) What is the value of $\frac{9231}{543 \times 1.7}$?

Circle the correct answer.

[1]

0.1

1

10

100

1000

.....

.....



11. (a) Write an expression for the n th term of the following sequence. [2]

2 7 12 17

.....

n th term =

(b) The first four diagrams in a sequence are shown below.

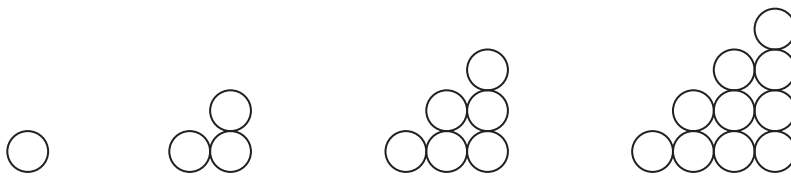

Diagram 1 Diagram 2 Diagram 3 Diagram 4

Complete the following subtraction. [1]

Number of circles in Diagram 17	-	Number of circles in Diagram 16	=	[]
------------------------------------	---	------------------------------------	---	-----

(c) The first three diagrams in another sequence are shown below.

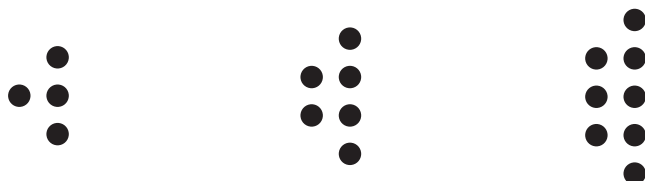

Diagram 1 Diagram 2 Diagram 3

Give an expression, in terms of n , for the number of dots (●) in Diagram n .
 You must simplify your expression. [2]

.....



12. (a) On each Venn diagram, shade the region that represents the given set.

(i) $A \cup B$

[1]

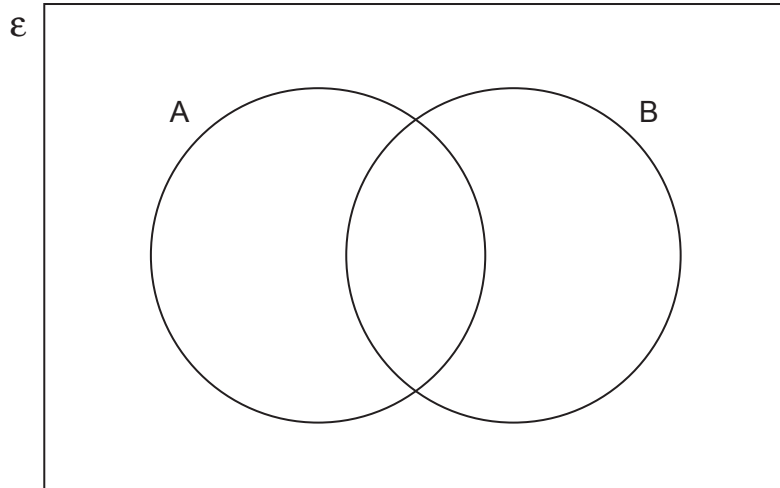

(ii) $A' \cap B$

[1]

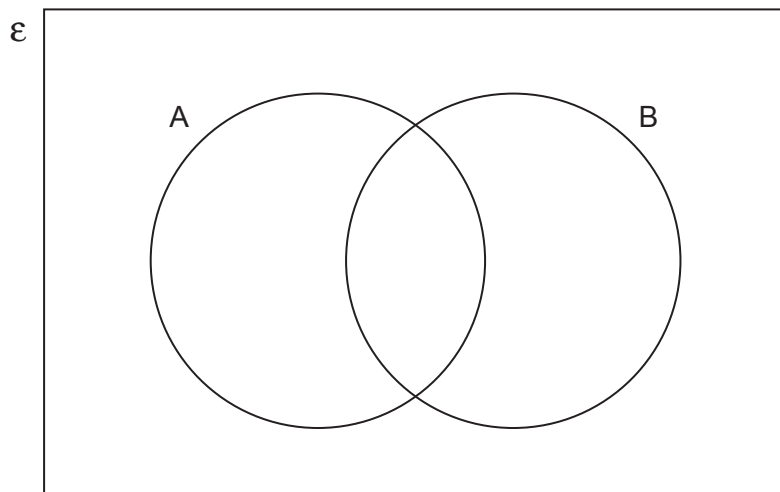

(b) In the Venn diagram below:

- Set A = multiples of 3,
- Set B = multiples of 5,
- Set C = multiples of 6.

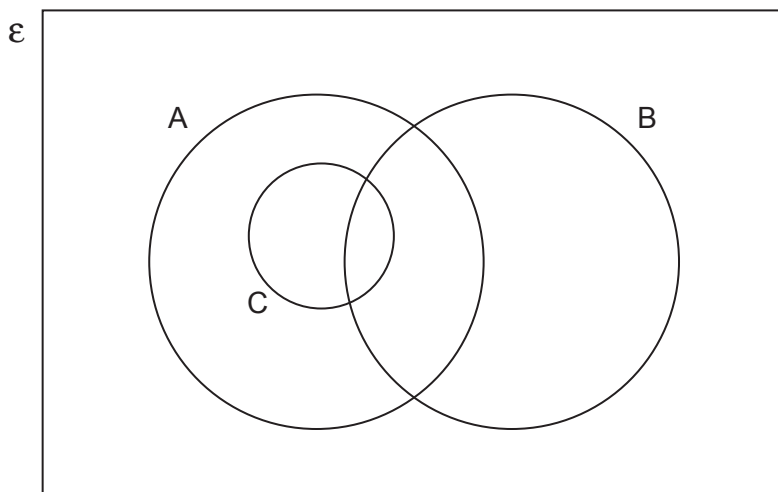

Explain why the circle representing Set C is drawn inside the circle drawn to represent Set A. [1]

.....

.....

.....

13. A sum of money is shared in the ratio 3 : 4 : 7.
The smallest share is £210.

What is the total amount of money shared?
You must show all your working.

[4]

.....

.....

.....

.....

.....

.....

.....

.....

.....



14. The table below shows some of the values of $y = x^2 - 4x - 3$ for values of x from -2 to 5 .

x	-2	-1	0	1	2	3	4	5
$y = x^2 - 4x - 3$		2	-3	-6		-6	-3	2

(a) Complete the table by finding the value of y for $x = -2$ and the value of y for $x = 2$. [2]

.....

.....

.....

.....

.....

.....

.....

(b) On the graph paper opposite, draw the graph of $y = x^2 - 4x - 3$ for values of x from -2 to 5 . [2]

(c) Draw the line $y = 1$ on the graph paper.
Write down the values of x where the line $y = 1$ cuts the curve $y = x^2 - 4x - 3$. [2]

Values of x are and



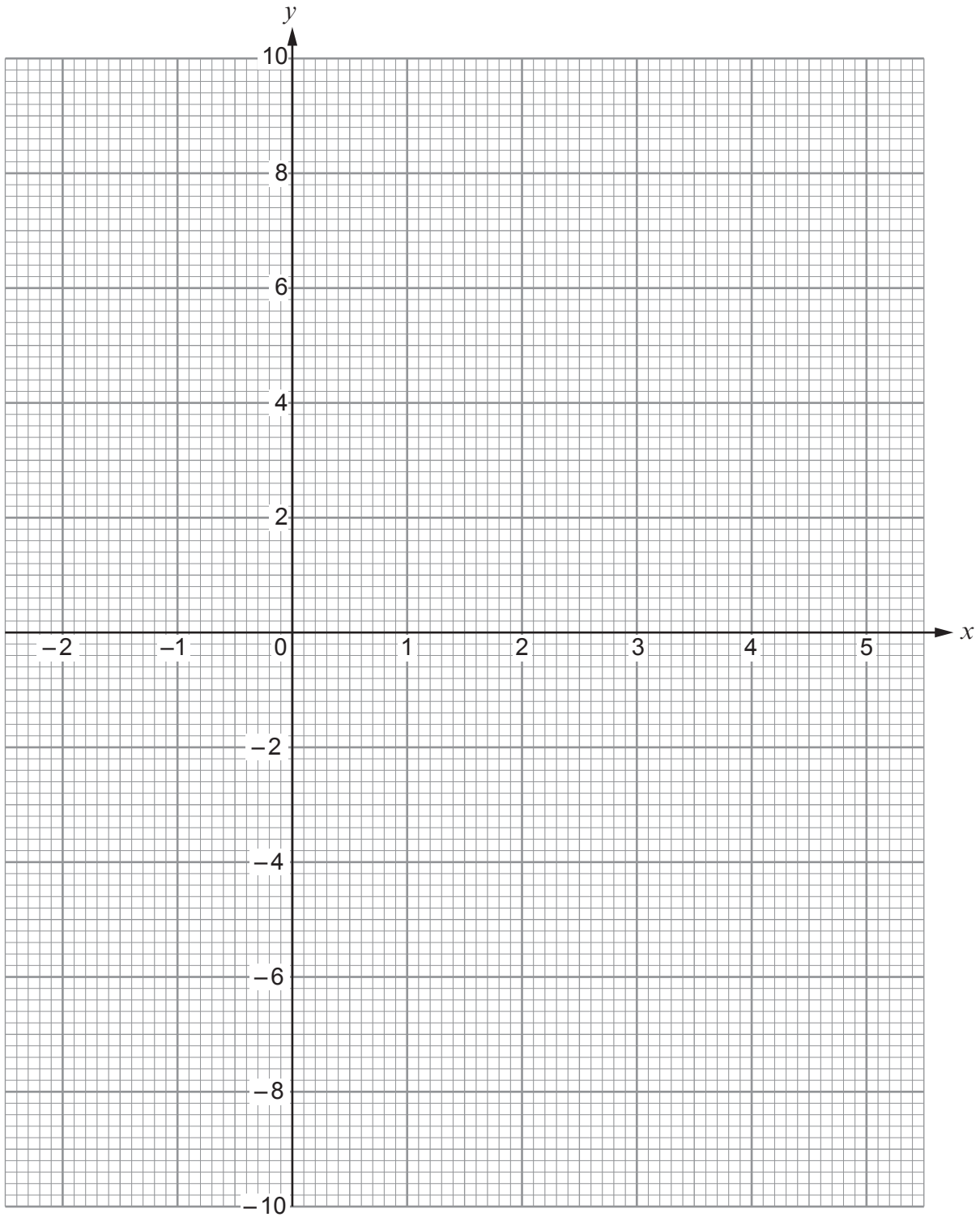

15. Find four **different** positive whole numbers so that:

- their mean is 8,
- their range is 8,
- their median is 8.

Write your four numbers in the boxes below.

[3]

.....

.....

.....

.....

.....

.....

.....

.....

.....

.....

.....

.....

.....

.....

.....

.....

.....

.....

.....

.....

.....

.....

.....

The four numbers are

--	--	--	--



16. (a) Factorise $x^2 - 7x + 12$, and hence solve $x^2 - 7x + 12 = 0$.

[3]

.....

.....

.....

.....

.....

(b) Expand and simplify $(5x - 2)^2$.

[2]

.....

.....

.....

.....

.....



17. Alice works for an engineering company.

A working day is chosen at random.

From keeping a record over the last year, Alice knows that, for this working day,

- the probability that she travels to work by car is 0.7,
- the probability that she arrives at work before 8:00 a.m. is 0.4,
- her time of arrival is independent of how she travels to work.

(a) Using the above information, draw and fully label a complete tree diagram.
You must include all probabilities.

[4]

(b) What is the probability that, on the randomly-chosen working day, Alice travels to work by car and arrives before 8:00 a.m.?

[2]

.....

.....

.....



18. A circle, centre O , has a radius of 4 cm.
 A and B are points on the circumference of the circle.
 Lines PA and PB are both tangents to the circle.
 $PB = 12$ cm.

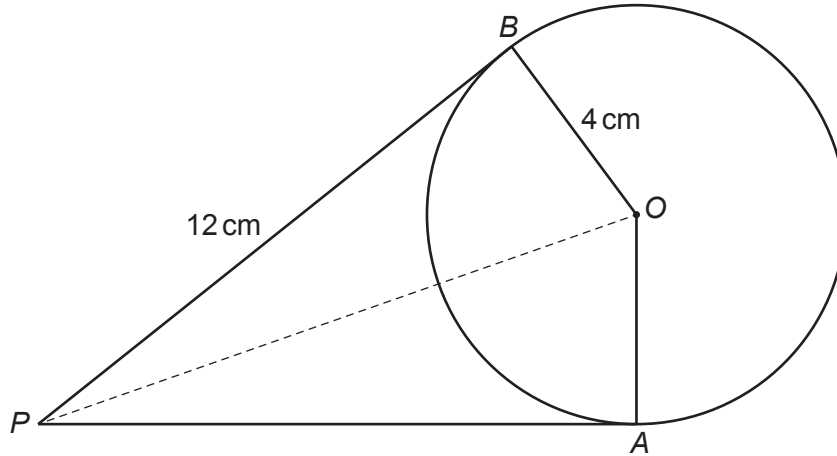

Diagram not drawn to scale

- (a) What is the length of PA ?
 State the circle theorem you have used to find your answer. [1]

$PA =$

Circle theorem:

- (b) What is the size of \hat{PAO} ?
 State the circle theorem you have used to find your answer. [1]

$\hat{PAO} =$

Circle theorem:

- (c) Calculate the area of the quadrilateral $PAOB$. [2]

.....

.....

.....

.....

.....



19. (a) Which one of the following equations represents a straight line that is parallel to the line $2y = 5x - 4$?
Circle your answer. [1]

$y = 2.5x + 3$ $y = 5x - 2$ $y = 0.4x - 4$ $y = -0.4x - 2$ $2y = -5x + 4$

.....

.....

- (b) Which one of the following equations represents a straight line that intersects the line $y = 7x - 5$ on the y -axis?
Circle your answer. [1]

$y = 7x + 5$ $y = 5 - 7x$ $y = 3x + 5$ $y = 0$ $y = 3x - 5$

.....

.....

(c)

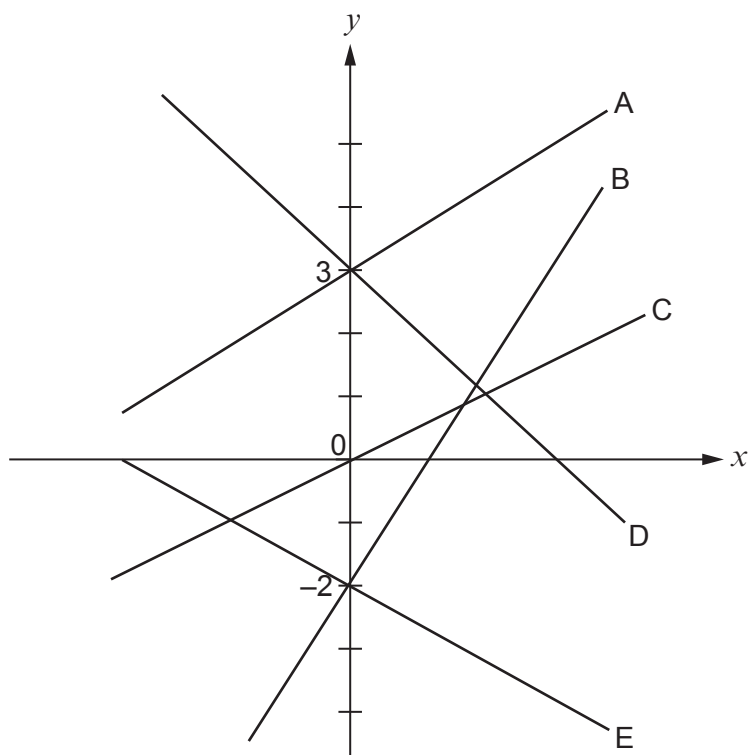

- Which one of the five straight lines shown above could represent the equation $y = -2x + 3$?
Circle your answer. [1]

Line A

Line B

Line C

Line D

Line E

END OF PAPER



BLANK PAGE

**PLEASE DO NOT WRITE
ON THIS PAGE**

